

Versatile Outdoor Enclosure Solution

The Remote Access Cabinet (RAC™) product family from Purcell Systems is as diverse and versatile as enclosures get. From 18" to 48", the RAC series of enclosures feature a variety of sizes and equipment rack space, and have a configuration ideal for every outside equipment deployment requirement you have.

From standard, off-the-shelf cabinets to modular, highly configurable enclosure systems, the RAC family can deliver exactly what you need and more.

Multiple configurations for:

- *Equipment protection*
- *Power management*
- *Battery runtime*
- *Ancillary equipment deployments*

Climate control systems including:

- *Direct Air Cooling*
- *Air Conditioning*

Adjustable components, mounting options, and a wide variety of kits and accessories provide exactly what you need to deploy your equipment in any environment or location.



RAC35 with direct air cooling option

Technical Specifications

Exterior Dimensions

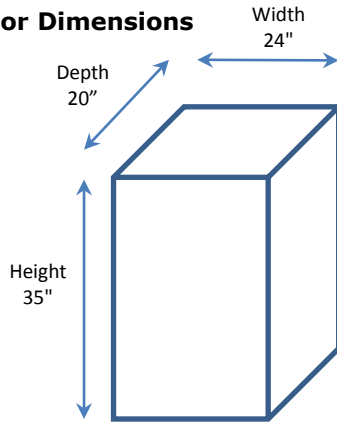

Interior Dimensions

- 32"H x 23"W x 19"D

Construction Materials

- Aluminum (lightweight, corrosion-resistant)
- Foil-backed insulation
- Paint: polyester powder coat

Door Construction

- Air intake opening with filter or cover plate
- Dual-point latched and pad lockable (padlock provided by end-user)
- Optional magnetic door alarm

Equipment Mounting

- 17RU of equipment space; 19" rack rails; front or mid mount

Thermal Management Options

- Air Conditioner: 2,000 BTU/hr; side mount
- Direct Air Cooling: 120VAC or 48V

DC Power System

- DC power management and rectifier options available

Mounting Options

- Pad mount
- Wall or H-frame mount
- Pole mount

Additional Options

- **Load center:** 8-position with 70A breaker
- **Battery backup:** -48V and +24V 17Ahr battery backup option
- **AC receptacles:** Duplex receptacles available for front and/or rear: (1) 20A Std, (1) 15A Std, (1) 20A GFI, (1) 15A GFI
- **Grounding:** Up to (2) 7-position ground bars; side and/or rear mount
- **Telco board:** 29" x 22.5" or 20" x 23" mounted in rear of cabinet
- **Equipment tray:** 19" with optional battery heater

Weight

- 65 lbs cabinet only
- 77 lbs cabinet with direct air cooling option
- 120 lbs with 2K air conditioner option
- Add 33lbs for shipping pallet

Agency Information

- UL508A NEMA 3R

Warranty

- 5 years enclosure/1 year thermal system



RAC35 with side mount air conditioner and optional AC load center

Purcell Systems, Inc.

16125 East Euclid Avenue Spokane, WA 99216 USA
Phone: 509.755.0341 www.purcellsystems.com